

Reversible Motor

180 watt

Frame Size : 90 x 90 mm

Specifications : 30 Minute Rating, TEFC Aluminium Body

Model	Output Power W	Frequency Hz	Supply Voltage V	Current A	Starting Torque Kg.cm	Rated Torque Kg.cm	Rated Speed RPM	Capacitor μ F
90 RW 2G180	180	60	Single phase 110 V	2.7	5.1	5.7	3000	20
90 RX 2G180	180	50	Single phase 230 V	1.35	6.3	6.9	2700	6
90 RY 4G180	180	60	Three phase 230 V	1.3	12.3	11.1	1600	
90 RY 4G180	180	50	Three phase 230 V	1.3	15.9	15.0	1350	
90 RZ 4G180	180	50	Three phase 415 V	0.7	15.9	15.0	1350	

The Product contains a built in thermal protector. When a motor overheats for any reason, the thermal protector is opened and the motor stops.

When the motor temperature drops, the thermal protector closes and the motor restarts.

Be sure to turn the motor off before inspection.

Gearmotor Torque Table :

The permissible torque is 200 Kg.cm.

50 HZ

Unit: kg.cm

RPM	500	416	300	250	200	166	120	100	83	60	50	41	30	25	20	16	15	13	10	8.3
Gear Ratio	3	3.6	5	6	7.5	9	12.5	15	18	25	30	36	50	60	75	90	100	120	150	180
Output Torque	36	42	60	70	88	106	134	160	192	200	200	200	200	200	200	200	200	200	200	200

60 HZ

Unit: kg.cm

RPM	600	500	360	300	240	200	144	120	100	72	60	50	36	30	24	20	18	15	12	10
Gear Ratio	3	3.6	5	6	7.5	9	12.5	15	18	25	30	36	50	60	75	90	100	120	150	180
Output Torque	28	34	48	56	72	86	106	128	155	197	200	200	200	200	200	200	200	200	200	200

The Gearheads are sold separately.

A Coloured background indicates gear shaft rotation in the same direction; a White background indicates rotation in the opposite direction as the motor shaft.

The Speed is calculated by dividing the motor's synchronous speed (50 Hz: 1500RPM, 60 Hz: 1800RPM) by the gear ratio.

The actual Speed is 2~20 % less than the displayed value, depending on the size of the load Characteristics, specifications and dimensions are subject to change without notice.

Dimensions

Motor, Gearbox with Terminal Box

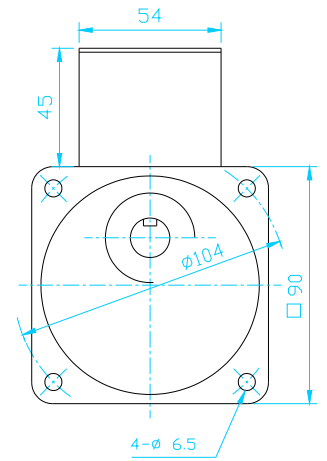
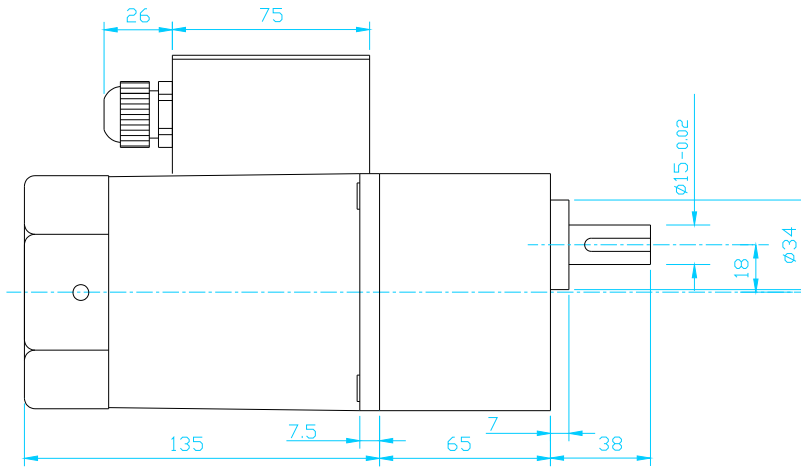

Motor Round Shaft with Terminal Box

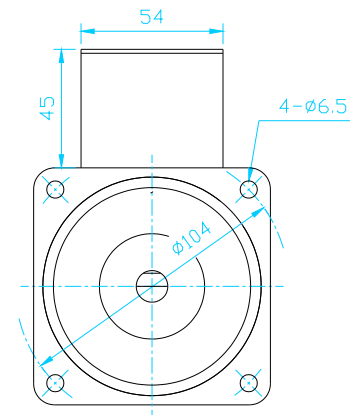
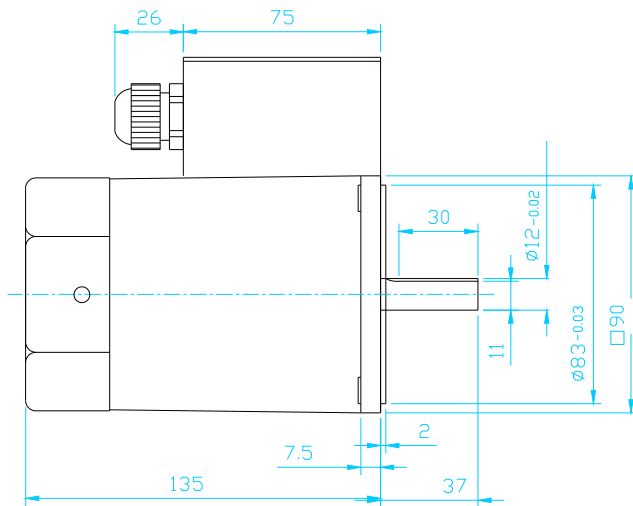

Motor, Gearbox with Leadwires

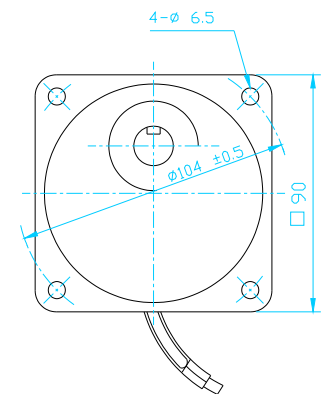
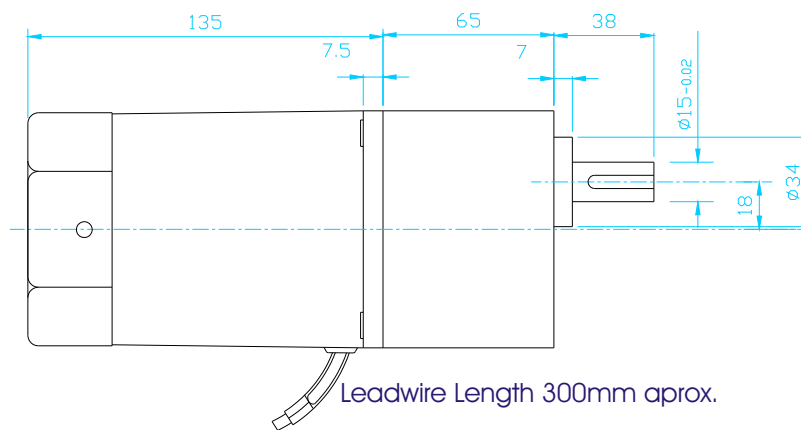

Key and Keyway

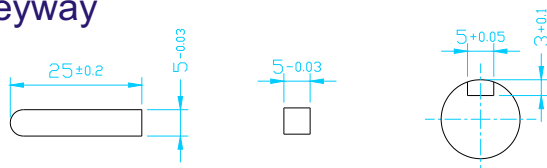

Weight: Motor :3 kg
Gearbox:1.5 kg

Wiring Diagram for Single Phase Motors

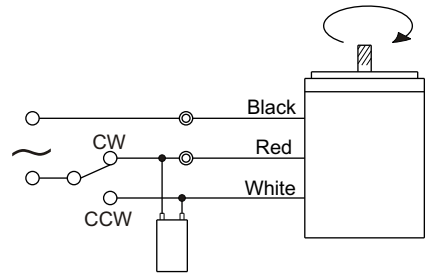
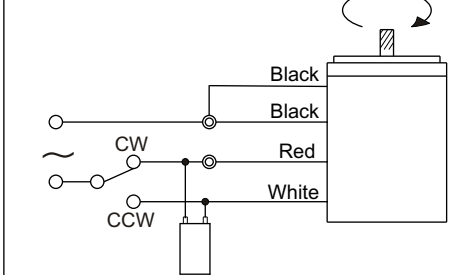
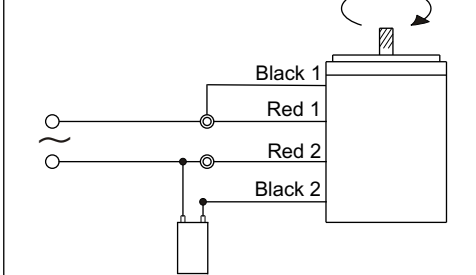
		
<p>Make the connections as shown to rotate the motor in clockwise direction</p> <p>To change the direction, flip SW to CCW</p>	<p>Short Black wires and connect as shown to rotate the motor in clockwise direction</p> <p>To change the direction, flip SW to CCW</p>	<p>Red wires are for running winding & Black wires are for starting winding</p> <p>To change the direction, interchange Black wires or Red wires</p>

Wiring Diagram for Three Phase Motors

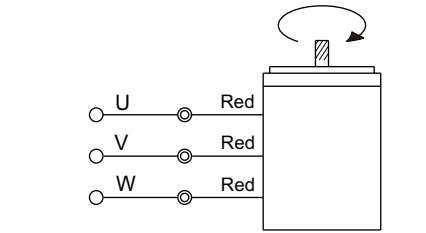
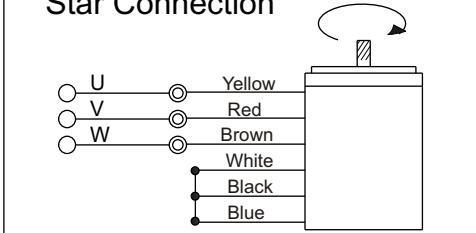
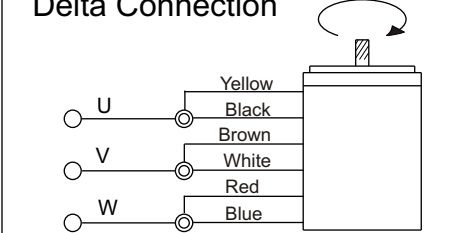
 <p>To change the direction, interchange any two wires between U, V & W</p> <p>For 415 Volt supply, wires are Red coloured For 230 Volt supply, wires are White coloured</p>	<h3>Star Connection</h3>  <p>To change the direction, interchange any two wires between U, V & W</p> <p>For 415 Volt supply, wires are connected as shown. Short White, Black & Blue wire and then insulate properly.</p>	<h3>Delta Connection</h3>  <p>To change the direction, interchange any two wires between U, V & W</p> <p>For 230 Volt 3 Ph supply, wires are connected as shown.</p>
--	--	--

Change the direction of the motor only after it stops rotating. If the attempt is made during rotation, motor may ignore the reversing command or change the direction after some time.