

# Performance.. at it's Peak !

## Magnetic Pump 12 LPM



### Features

- Very compact, Sleek, Splash proof design
- Suitable to almost all chemicals
- Sealless pump means no contamination
- PP chamber makes it corrosion resistant
- High efficiency, High performance, Low heating
- Centrifugal, non self priming Pump

### Applications

Chemical Circulation in Industries, Electroplating equipment, Medical equipment, Galvanizing facilities, pure water plants, Water treatment plants, Ice makers, Soft drink dispensers, Boilers, Heat exchangers, Solar systems, Dye bath, Wafer processors, Home aquariums, Fountains, Color-Black & White film processors, X - ray film processors, Silver recovery systems, Graphic arts processors, etc.

### Specifications

**Supply Voltage** : 230 / 110 V 50/60 Hz 1 Ph,  
: 230 / 440 V 50/60 Hz 3Ph

**Power Input** : 15 Watt

**Max. Discharge** : 12 Liter / Min.

**Max. Head** : 1.8 Meter

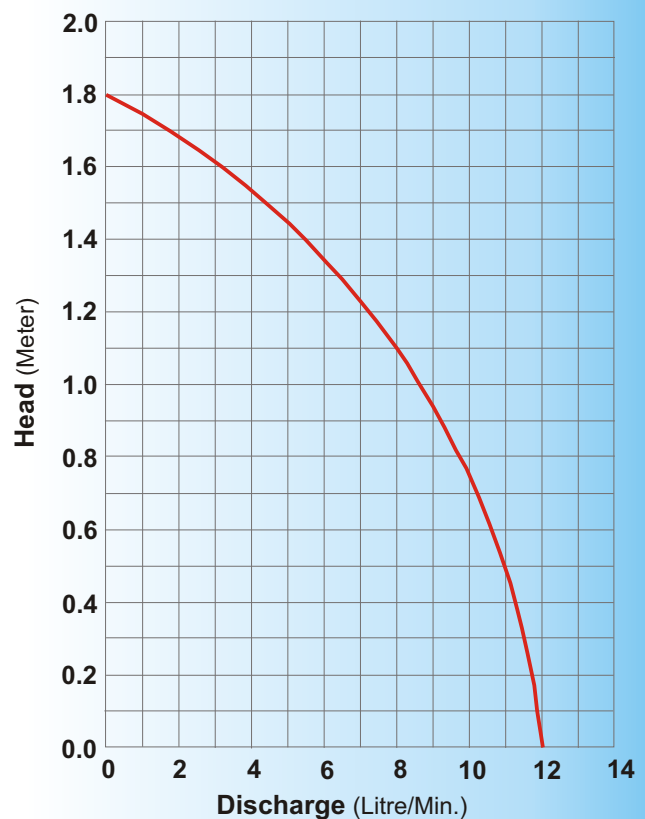

# Magnetic Pump

12 LPM

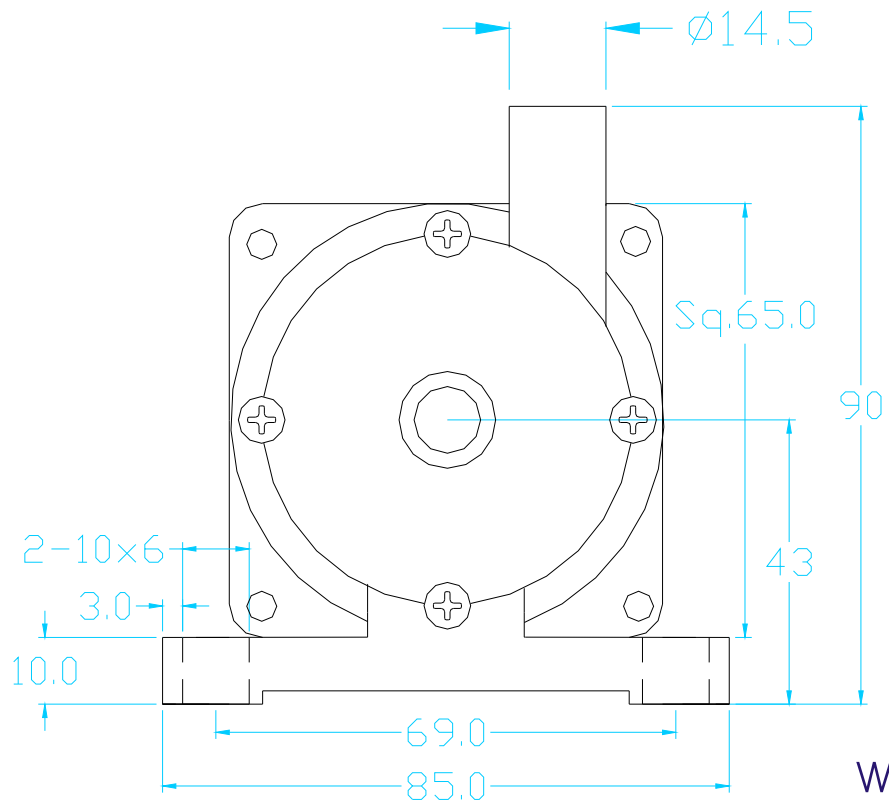
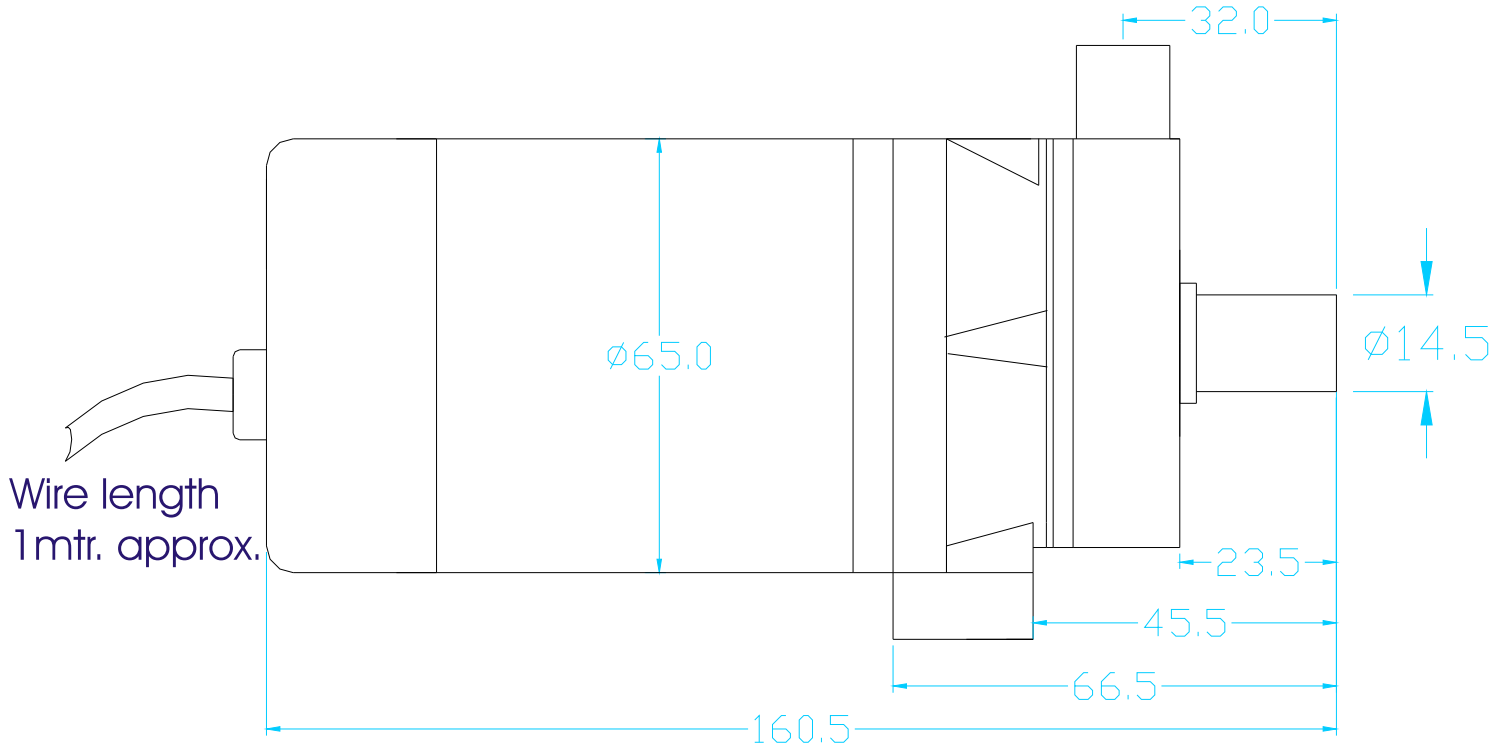

Weight : 1.2 Kg