

Induction Motor

40 watt

Frame Size : 90 x 90 mm

Continuous rating, TE Aluminium body

Rotates in clockwise or counter clockwise direction. Direction of rotation can be reversed

Overruns for a few rotation after supply is cut off

Speeds are 2880 / 1440 RPM and further low speeds with gearbox

Terminal box or open lead wires for connection

Model	Output Power W	Frequency Hz	Supply Voltage V	Current A	Starting Torque Kg.cm	Rated Torque Kg.cm	Rated Speed RPM	Capacitor μ F
90 IW 4G 40	40	60	Single phase 110 V	0.7	2.1	2.5	1500	4
90 IX 4G 40	40	50	Single phase 230 V	0.33	2.7	3.0	1250	1.85
90 IY 4G 40	40	60	Three phase 230 V	0.46	2.5	2.5	1500	
90 IY 4G 40	40	50	Three phase 230 V	0.54	2.9	2.8	1320	
90 IY 4G 40	40	50	Three phase 415 V	0.3	2.9	2.8	1320	

Gearmotor Torque Table :

The maximum permissible torque is 200 kg.cm

50 HZ

Unit: kg.cm

RPM	500	416	300	250	200	166	120	100	83	60	50	41	30	25	20	16	15	12.5	10	8.3
Gear Ratio	3	3.6	5	6	7.5	9	12.5	15	18	25	30	36	50	60	75	90	100	120	150	180
Output Torque	7.3	8.7	12	15	18	22	30	36	44	55	66	79	99	118	145	177	195	200	200	200

60 HZ

Unit: kg.cm

RPM	600	500	360	300	240	200	144	120	100	72	60	50	36	30	24	20	18	15	12	10
Gear Ratio	3	3.6	5	6	7.5	9	12.5	15	18	25	30	36	50	60	75	90	100	120	150	180
Output Torque	6.3	7.6	11	13	16	19	26	32	38	47	57	68	86	102	121	149	180	200	200	200

The Gearheads are sold separately.

A Coloured background indicates gear shaft rotation in the same direction; a White background indicates rotation in the opposite direction as the motor shaft.

The Speed of Geared Motor is calculated by dividing the motor's synchronous speed (50Hz: 1500RPM, 60 Hz: 1800RPM) by the gear ratio.

The actual Speed is 2~20 % less than the displayed value, depending on the size of the load. Characteristics, specifications and dimensions are subject to change without notice.

Dimensions

Motor, Gearbox with Terminal Box

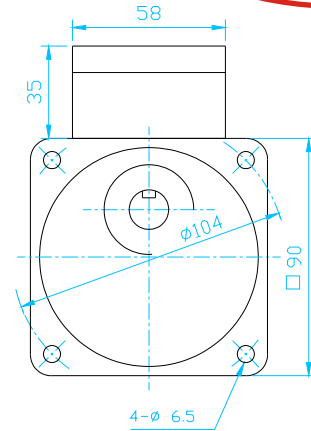
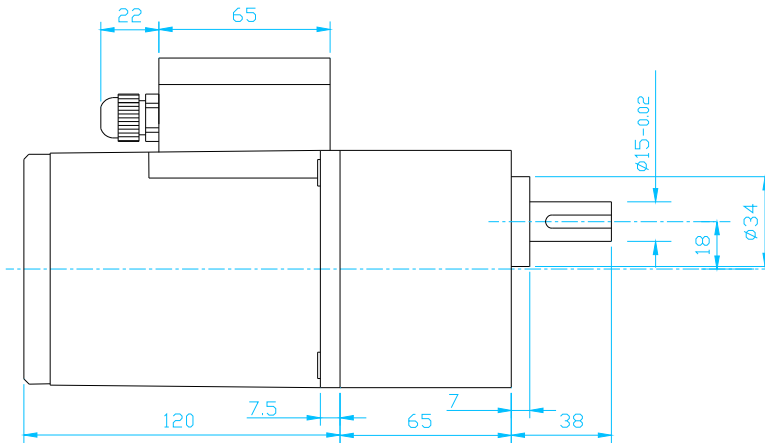

Motor Round Shaft with Terminal Box

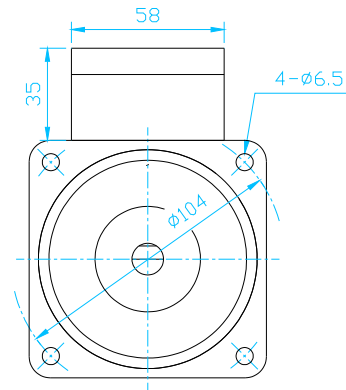
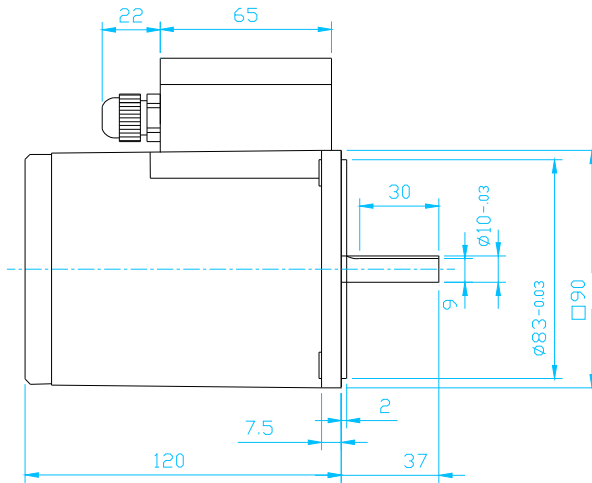

Motor, Gearbox with Leadwires

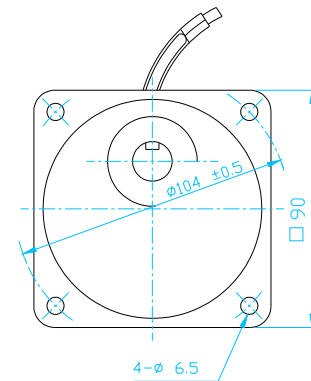
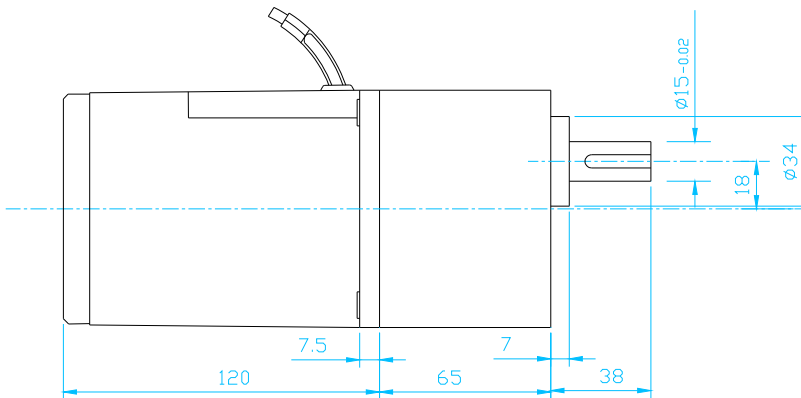

Key and Keyway

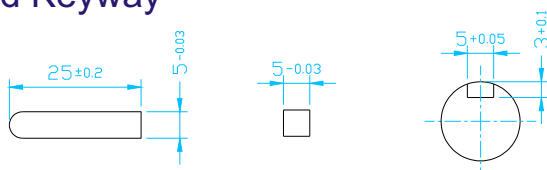

Weight: Motor : 2.2 kg
Gearbox: 1.5 kg

Wiring Diagram for Single Phase Motors

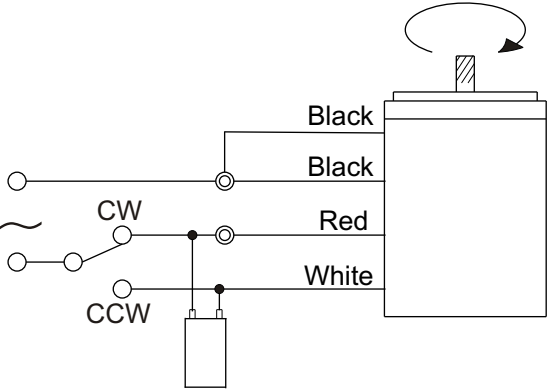
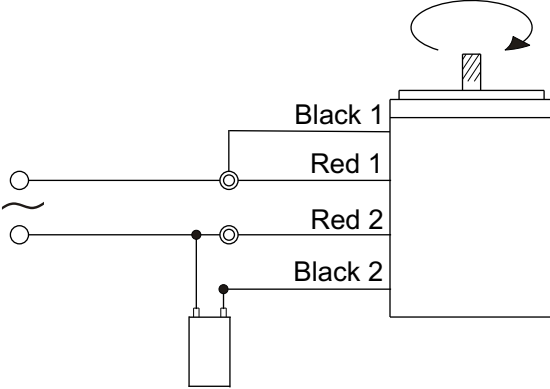
	
<p>Short Black wires and connect as shown to rotate the motor in clockwise direction</p> <p>To change the direction, flip SW to CCW</p>	<p>Red wires are for running winding & Black wires are for starting winding</p> <p>To change the direction, interchange Black wires or Red wires</p>

Wiring Diagram for Three Phase Motors

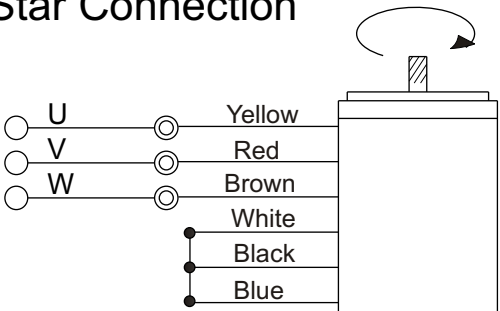
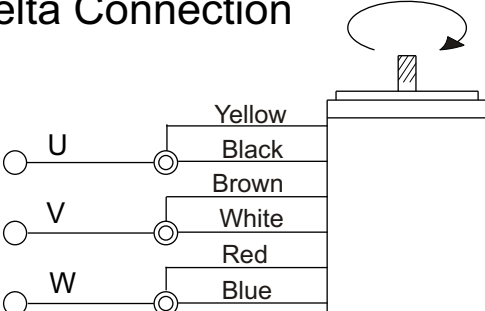
<p>Star Connection</p> 	<p>Delta Connection</p> 
<p>To change the direction, interchange any two wires between U, V & W</p> <p>For 415 Volt supply, wires are connected as shown. Short White, Black & Blue wire and then insulate properly.</p>	<p>To change the direction, interchange any two wires between U, V & W</p> <p>For 230 Volt 3 Ph supply, wires are connected as shown.</p>

Change the direction of the motor only after it stops rotating. If the attempt is made during rotation, motor may ignore the reversing command or change the direction after some time.